

Model G7-80 Rotary Gear Pump

Surex rotary gear pumps designed for foam extinguishing system. They are Self-Priming and can pump Multiple Viscosities of Foam or Water. This versatile design is suitable for Electric, PTO, Diesel/Gasoline Engine, Water Driven or Hydraulic drive motors.

Design Features:

- Timing Gears Synchronize the Two Pumping Rotors.
- Timing Gears Allow for DRY Running Without Damage.
- No Rotor Contact Allows for Pumping Foam or Water.
- Water Can Be Used for: Calibration, Testing and Training.

Technical Data:

Max Pressure: 2.0MPa | 20bar
 Max Speed: 1800RPM
 Viscosity : 9500cp max.[1]
 Connection Diameter: DN50(60.3 O.D.)、2"
 Connection Type: Groove、Thread、Flange
 Approvals: FM
 [1]Brookfield viscometer, spindle #4, speed 30rpm.

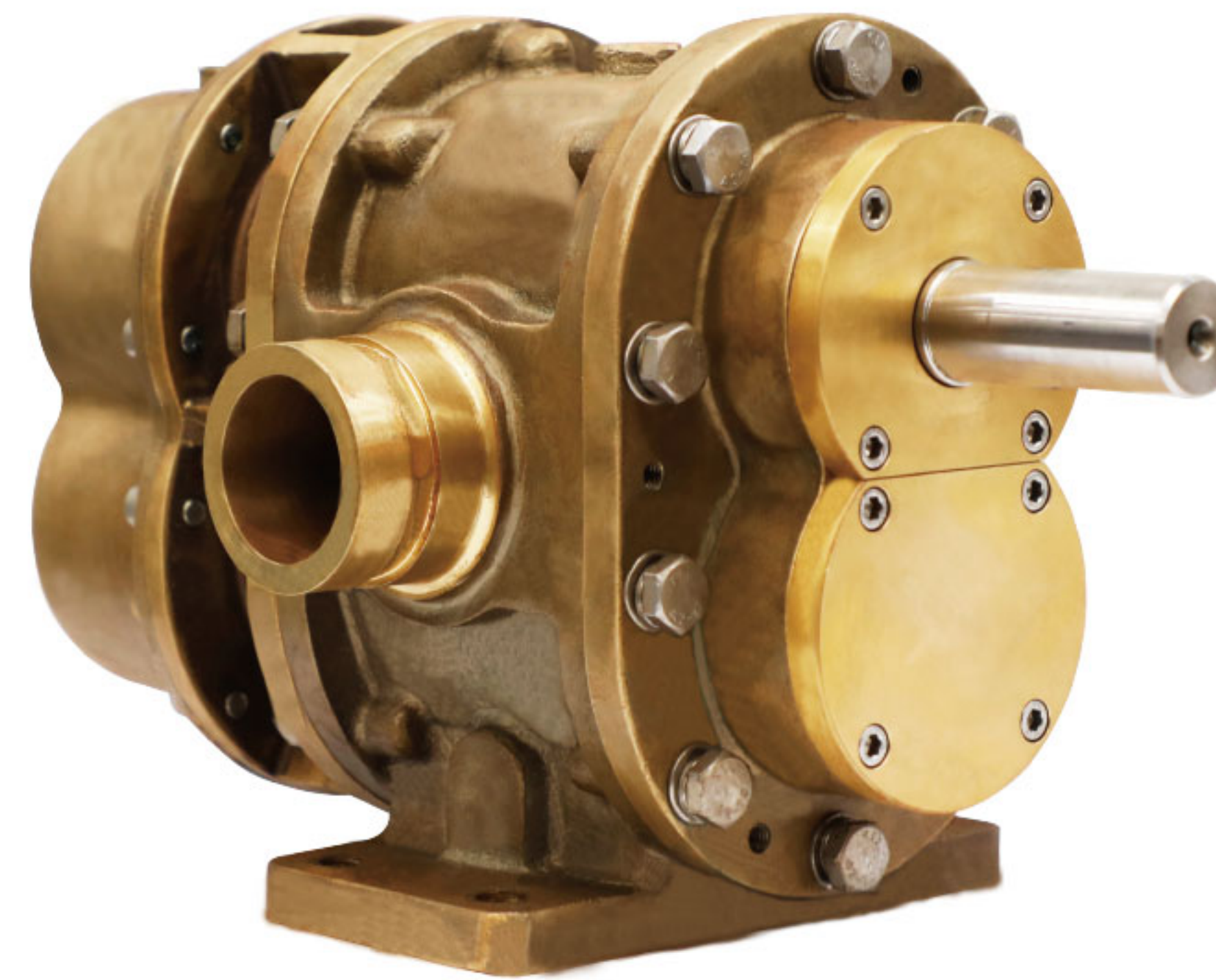

Materials :

Pump body: Red Brass, ASTM B584 C83600
 Rotor: Stainless Steel 17-4PH
 Red Brass, ASTM B584 C83600
 Liners: Red Brass, ASTM B584 C83600
 Front Cover: Red Brass, ASTM B584 C83600
 Back Cover: Red Brass ASTM B584 C83600
 Timing Gear: Alloy Steel 20CrMnTi (ASTM A29M)
 Lip Seal : FPM

Performance -Water

Foam Pump	1000rpm			1200rpm			1500rpm			1800rpm			
	Pressure	Flow	Power	Torque	Flow	Power	Torque	Flow	Power	Torque	Flow	Power	Torque
	bar	L/min	kw	N.m	L/min	kw	N.m	L/min	kw	N.m	L/min	kw	N.m
	5.0	168	3	29	221	4	30	299	5	33	379	7	35
	6.9	154	4	37	206	5	38	284	6	40	364	8	42
	10.3	132	5	51	184	7	52	262	8	53	341	11	56
	13.8	114	7	66	167	8	66	244	11	68	323	13	71
	17.2	102	8	80	155	10	80	231	13	82	310	16	86
	20.0	95	9	91	148	12	92	223	15	93	302	18	97

Dimensions

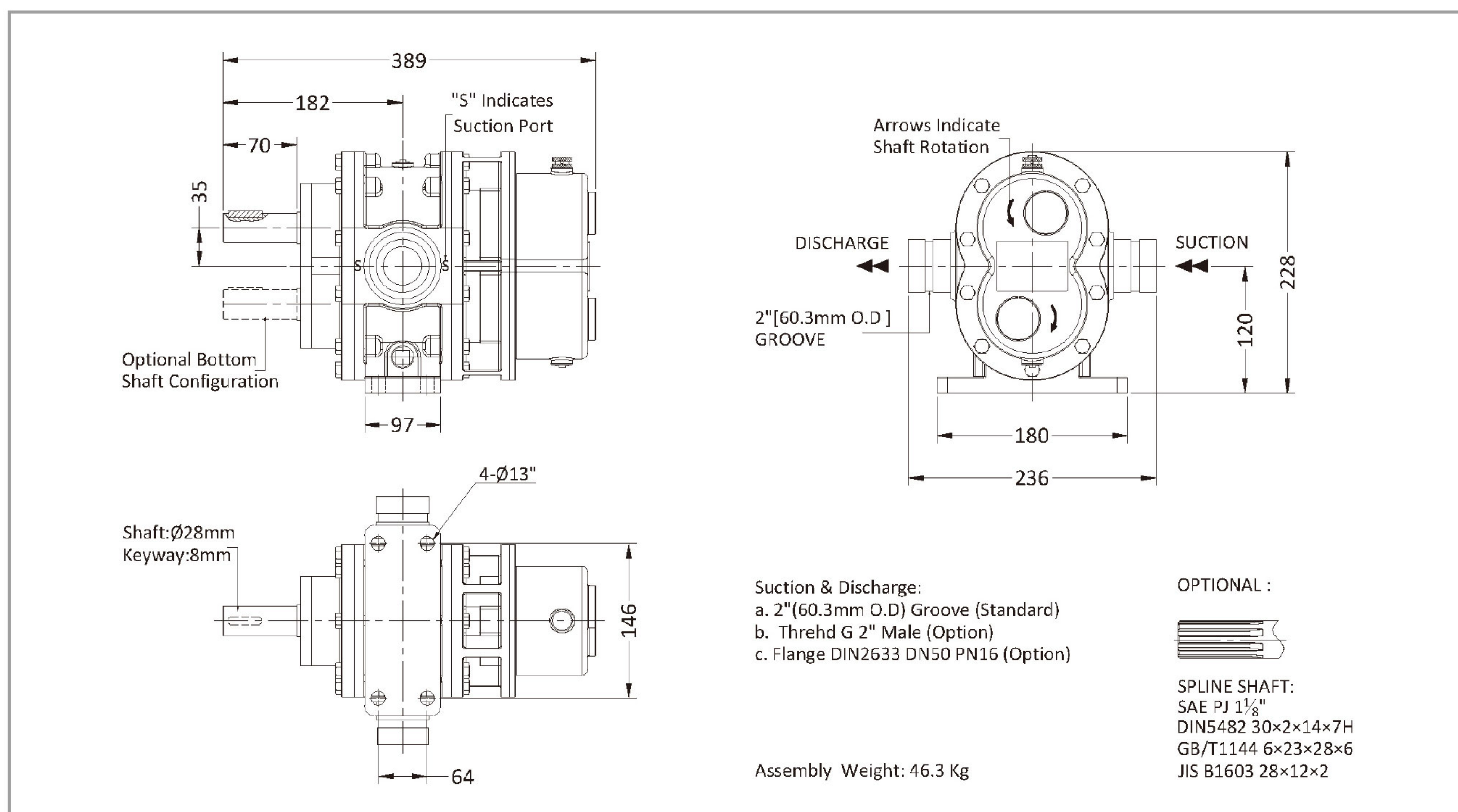

Model G7-80 Rotary Gear Pump

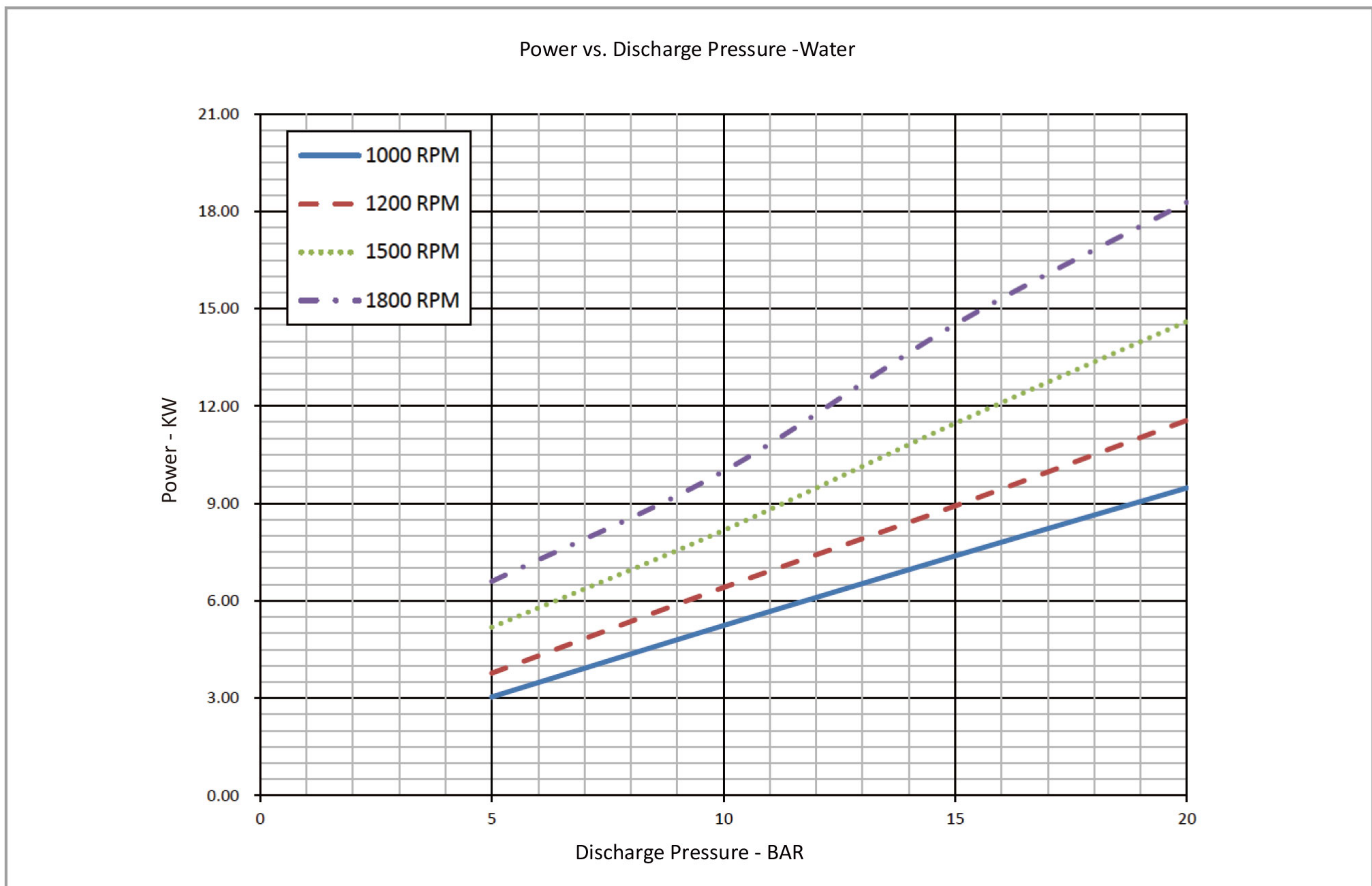
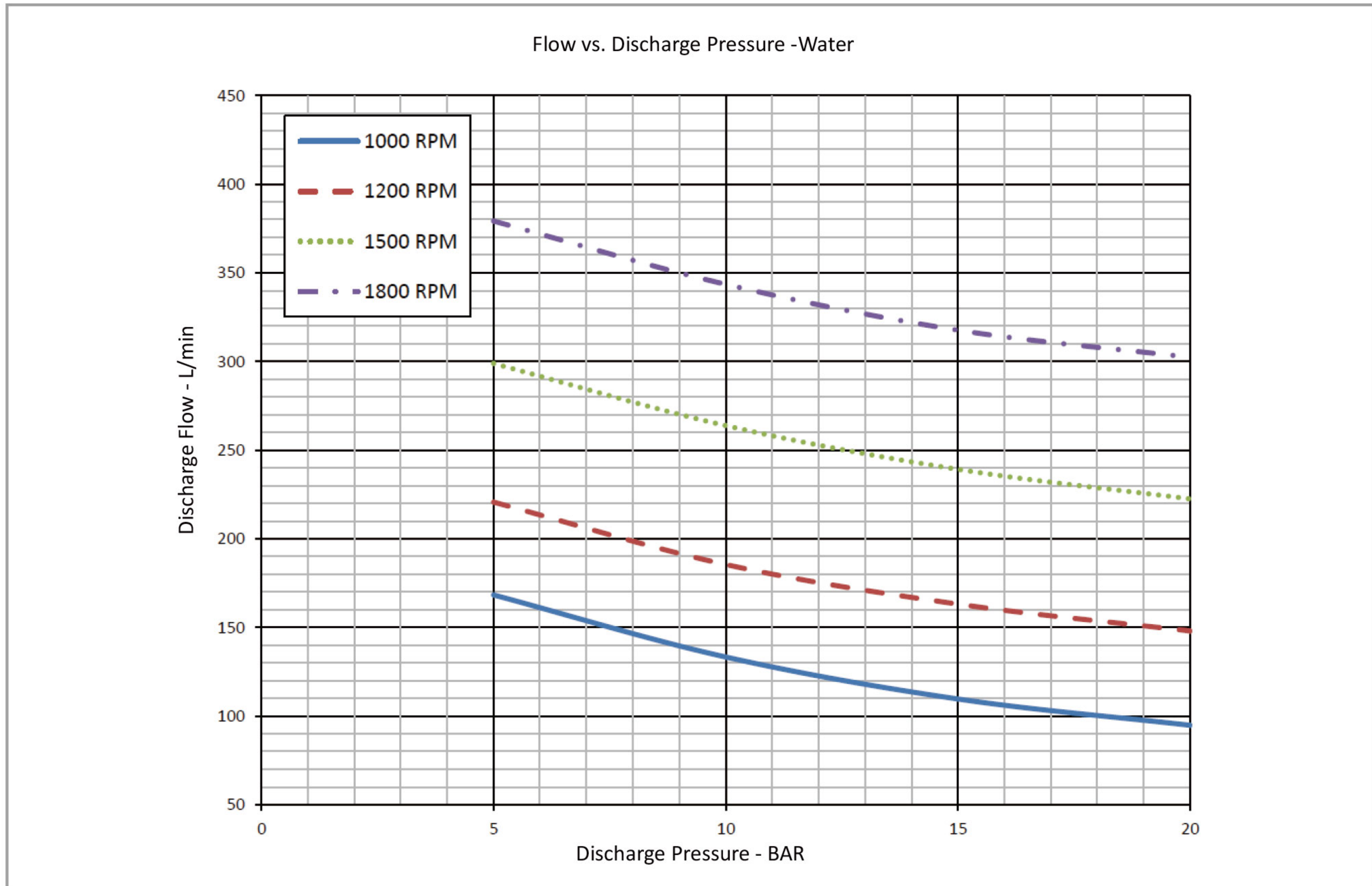

• The pump performance for foam concentrate, please contact Surex, or down load from www.surexfoam.com.